

Flush-mounted distribution box GRIMM BIG 515B-GS - SCHUKO - CEE - RAL of your choice | ? RAL of your choice

Product number 515B-GS-E-RAL



Product description

Flush-mounted distribution box GRIMM BIG 515B-GS - SCHUKO - CEE

High-quality distribution box for the internal mounting of multiple socket outlets. The distribution box is made entirely of stainless steel V2A 1.4301. The distribution box is supplied without equipment components. Can be fitted with ready-to-connect socket strips (SCHUKO, CEE 16A 5 p 400V, CEE 16A 3 p 230V). Customised equipment possible on request.

Thanks to the distribution box, the equipment components can be stored inside, protected from the weather. The cable is fed out of the lower opening when in use so that the door can be closed again. This guarantees a sleek and modern look and your equipment components are perfectly protected.

Thanks to the design, self-assembly is uncomplicated.

- Flush-mounted distribution box made of 2 mm stainless steel V2A 1.4301, either polished or powder-coated in a RAL colour of your choice.
- Quality production - Made in Germany - Letterbox Manufaktur Lippe.
- Front removal door 365 mm x 637 mm, opens from left to right.
- The removal door is equipped with damped stainless steel hinges for extremely long durability.
- Optionally with lever lock, toggle lock or RFID lock.
- Flush-mounted box dimensions: H 710 mm x W 410 mm x D 150 mm. Flush-mounted box with pre-punched cable inlets and fixing points on all sides.

Product properties

Series	GRIMM
Charging connection	CEE, SCHUKO
Mounting type	Free-standing
Material	Stainless steel V2A 1.4301
Surface/colour	Brushed

Dimensions

Height of single box in mm	710,0 750,0
Width of single box in mm	410,0 450,0
Capacity in litres	44
Depth in mm	150,0
Weight in kg	32
Delivery condition	Supplied fully assembled

Drawing

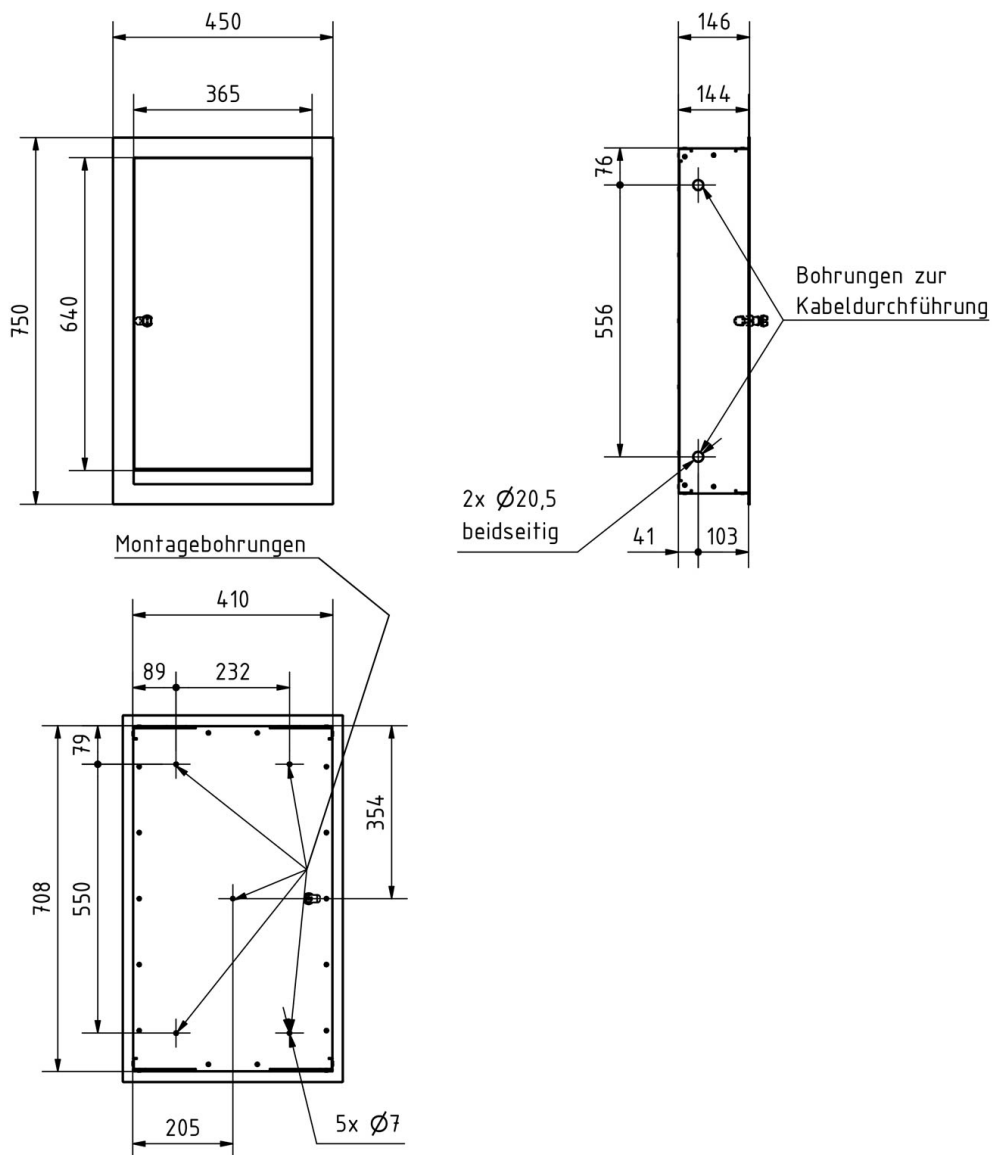

More images

