

# KANT Edition letterbox with newspaper compartment - Elegance 1 design - RAL 9005 jet black | RAL 9005 deep black fine structure matt

Product number 303-9005VA-AP



## Product description

### KANT Edition letterbox with newspaper compartment - Elegance 1 design - RAL 9005 jet black

The KANT Edition letterbox combines **elegant design** and functional convenience in one product. Its minimalist design with invisible lock and stylish labelling option fits seamlessly into modern living environments. You can rely on **long-lasting quality** thanks to our excellent choice of materials and precise workmanship.

The generous capacity of around 12 litres and top-loading ensures crease-free mail - even with DIN C4 envelopes and magazines. For added convenience, the letterbox is equipped with **high-quality axle dampers** that allow the flap to close gently and quietly. The newspaper compartment of this letter box offers maximum functionality with double-sided posting, ideal for modern everyday life. The scope of delivery includes a cover that can be retrofitted, giving you the option of reliably closing the weather side.

Thanks to the design, self-assembly is uncomplicated.

- High-quality surface-mounted letterbox made of galvanised steel, powder-coated in RAL 9005 deep black fine structure matt.
- Elegance 1 design: stainless steel trim, 240 grit polished.
- The door can be opened from top to bottom.
- Insertion from above, insertion flap with high-quality axle dampers for silent closing.
- Includes 2 keys with key number.
- The letterbox complies with DIN/EN 13724. Insertion size (3.5 cm x 33.5 cm) for C4 landscape, large letters also fit in here without creasing.
- Newspaper compartment (BH 360x110mm) made of galvanised steel, powder-coated in RAL 9005 deep black fine structure matt. Open on both sides (1x cover included).
- Optional name lettering approx. 8-25mm high.
- Optional house number labelling approx. 60-80mm high.
- For surface wall mounting including mounting screws.

#### Important information:

To achieve optimum water protection for your mail, the letterbox or letterbox system should be located under a canopy if possible.

The mail is only protected from water if it is fully inserted in the box and the flap is closed. Mail that is not fully inserted allows moisture and dirt to enter the letterbox. This system is protected against the ingress of water in accordance with DIN EN 13724. Water ingress is not a reason for complaint.

## Product properties

<b>Material</b>	Steel, galvanised, Stainless steel V2A 1.4301
<b>Surface/colour</b>	RAL 9005 deep black, Brushed
<b>Series</b>	KANT
<b>Functions</b>	Newspaper compartment
<b>Boxes by volume</b>	Normal > 10 litres
<b>House number</b>	House number as laser engraving
<b>Name labelling</b>	Laser-engraved
<b>Removal of mail</b>	On the front
<b>Number of boxes</b>	with 1 letterbox
<b>Mounting type</b>	Surface-mounted

## Dimensions

<b>Height of single box in mm</b>	BK 280.0   ZF 110.0
<b>Width of single box in mm</b>	355,0
<b>Capacity in litres</b>	12
<b>Height of letterbox slot in mm</b>	35,0
<b>Width of letter slot in mm</b>	335,0
<b>Height of letterbox in mm</b>	412,0
<b>Width of letterbox system in mm</b>	372,0
<b>Total width in mm</b>	372,0
<b>Depth in mm</b>	110.0 + 21.0 Aperture
<b>Weight in kg</b>	6
<b>Delivery condition</b>	Supplied fully assembled

Drawing

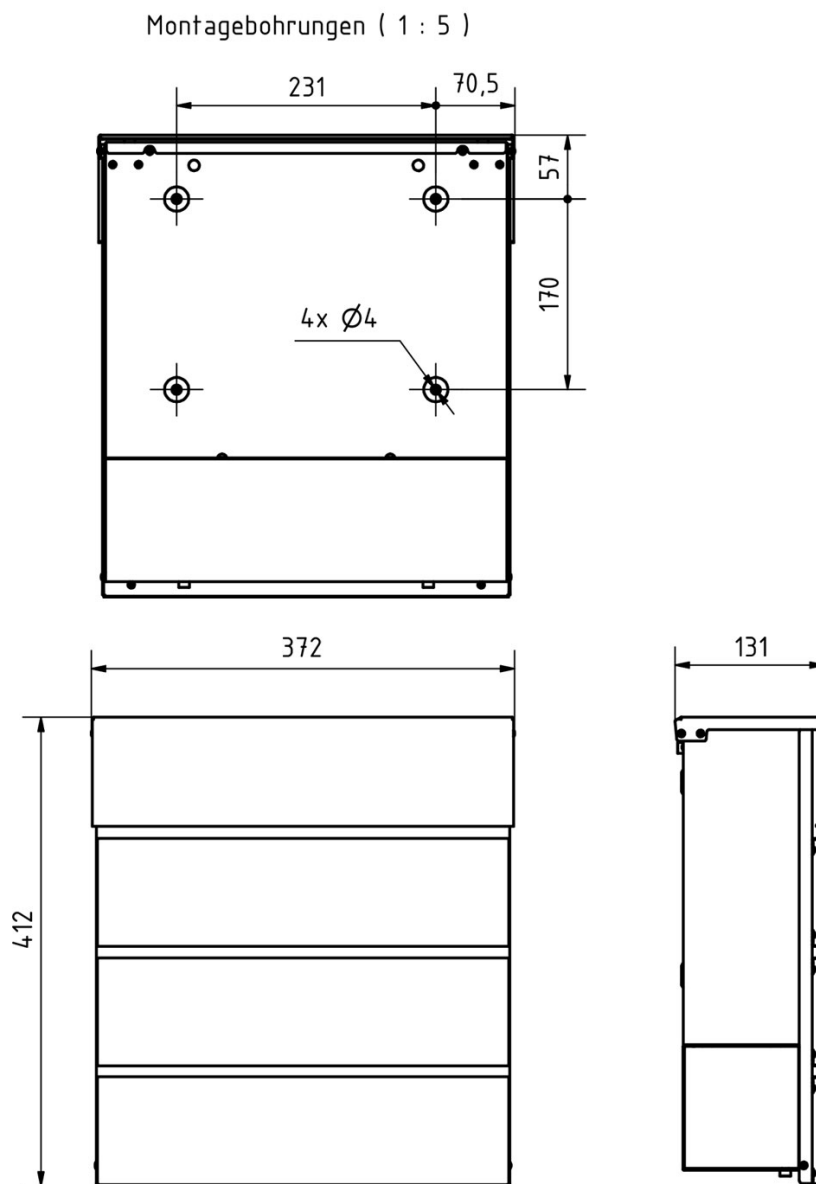

## More images





