

Stainless steel letterbox with DoorBird video intercom - 350x63mm - 410x375mm - RAL of your choice | ? Colour of your choice

Product number 555-BEKA-35-VAR-KSDBE



Product description

Stainless steel letter slot with DoorBird video intercom - slot 350x63mm - 410x375mm

High-quality manufactured letterbox cover with letter slot from Briefkasten Manufaktur. Integrated DoorBird IP Video Door Station D2100E or D1100E. The DoorBird IP Video Door Station D2100E or D1100E is the smart solution for your entrance door. The IP video door station can be operated as a stand-alone unit or integrated into an existing smart home platform. Existing, classic installations such as a door chime or an electric door and gate opener can also continue to be used with DoorBird and controlled via the app.

This is a real eye-catcher among letterboxes. Clean lines and no-frills design characterise the designer letterbox collection. Our products have a high quality, reliable functionality and their own identity. Made by Briefkasten Manufaktur. The DoorBird was not only invented and developed in Germany, but is still produced in Berlin today. At DoorBird, "Made in Germany" is not just a seal, but a philosophy that is lived and breathed. The IP video door stations are manufactured in the DoorBird factory to guarantee the highest quality, durability and customer satisfaction.

- Stainless steel letter slot made of 2 mm stainless steel V2A 1.4301, powder-coated in RAL colour.
- The insertion flap is produced at the letter box manufactory. German quality production "Made in Germany".
- Insertion size suitable for C4 landscape. Very large letters and magazines fit in here without creasing.
- Optionally with house number, backlit in white incl. EVN LED power supply unit / transformer IP65 12V/DC 0.1-4W for LED illumination of the house number.
- Incl. DoorBird IP video door station D2100E or D1100E installed.
- Fastened using four stainless steel screws incl. plugs supplied.

Important information

Camera or intercom preparation

The intercom systems must be connected by an electrician. Please contact your trusted electrician for planning, fitting and installation.

Water protection

To achieve optimum water protection for your mail, the letterbox or letterbox system should be located under a canopy if possible.

The mail is only protected from water if it is fully inserted in the box and the flap is closed. Mail that is not fully inserted allows moisture and dirt to penetrate the letterbox. It is therefore necessary to plan sufficiently dimensioned letterboxes for the upcoming requirements. In certain extreme weather conditions, water can still enter (up to 1ccm according to DIN EN 13724). This is not a reason for complaint.

Product properties

Surface/colour	RAL 9005 deep black, RAL 3004 crimson red, DB 703 iron mica, RAL 7016 anthracite grey, RAL of your choice (according to colour table), RAL 9007 grey aluminium, RAL 9016 traffic white
Connection technology	LAN
Number of bell push buttons	1 button
Functions	Camera, Intercom
Mounting type	Screw
Boxes by volume	Normal > 10 litres
Material	Stainless steel V2A 1.4301
Name labelling	Laser-engraved
Number of boxes	with 1 letterbox
Removal of mail	On the back

Dimensions

Width in mm	410
Height in mm	375
Height of letterbox slot in mm	63,0
Width of letter slot in mm	350,0
Weight in kg	8
Delivery condition	Delivery is assembled

Drawing

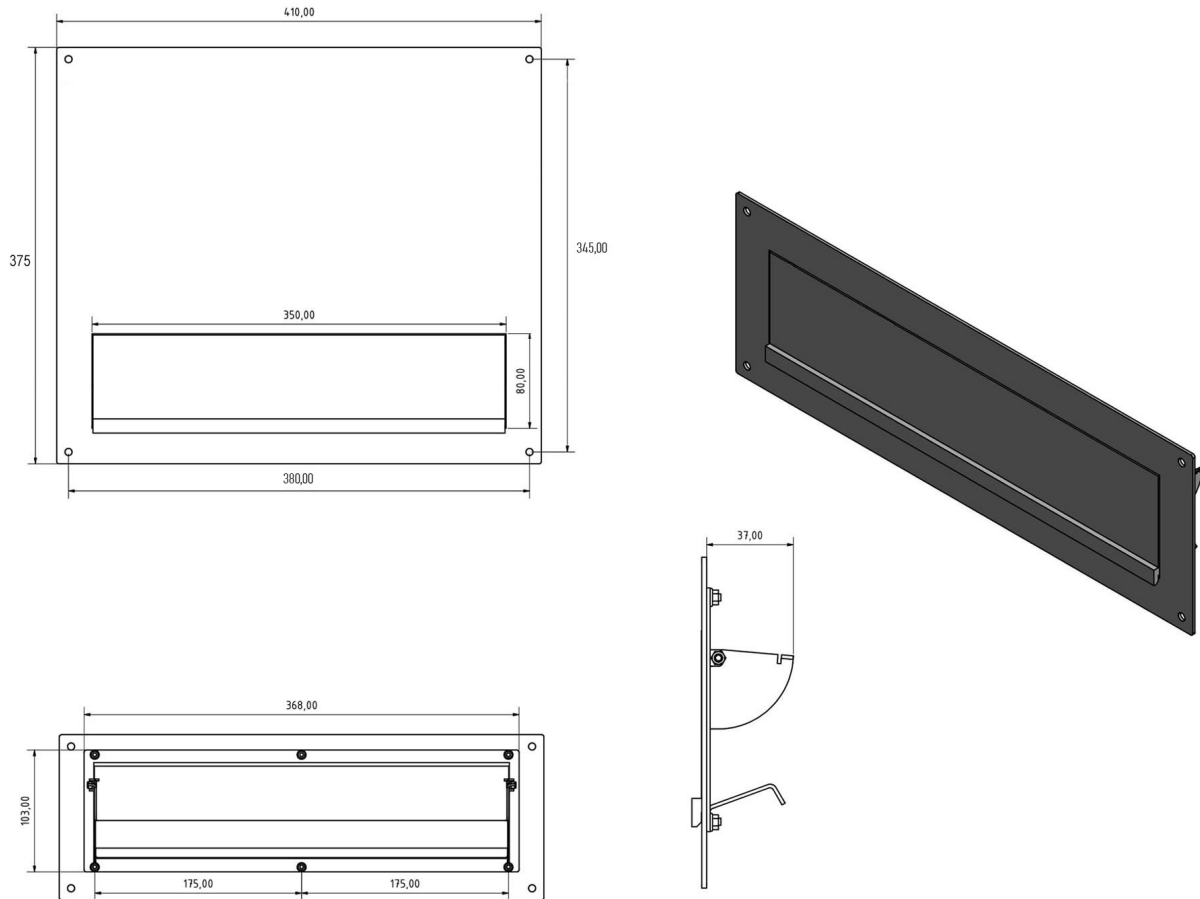

More images

